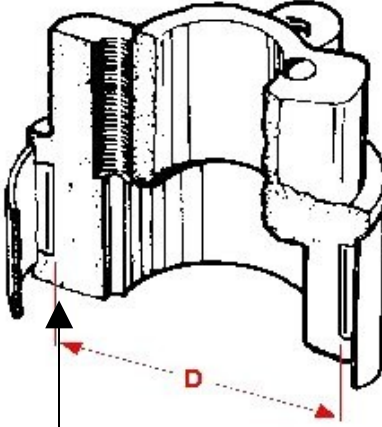
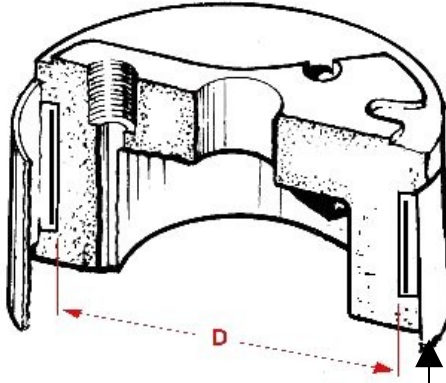

TO BE COMPLETED BY CUSTOMER				
CUSTOMER ADDRESS				
CUSTOMER ORDER REF				
CUSTOMER AUTHORISATION				
<div style="display: flex; justify-content: space-around;"> <div style="text-align: center;"> <p>O-MATIC STD</p>  </div> <div style="text-align: center;"> <p>HANDAMATIC / MINOR</p>  </div> </div> <p style="text-align: center; margin-top: 10px;">VOLTAGE AND WATTS STAMPED EITHER ON S/S BAND OR INTO CASTING</p>				
MODEL	VOLTAGE	WATTS	DESCRIPTION	DIAMETER
O-Matic	240	250	2 ½ Custard Die TP123	SAMPLE